

DATI TECNICI

Pos.	Metrico (mm)		Imperiali (Feet)	
	A25E	A30E	A25E	A30E
A	10 220	10 297	33'6"	33'9"
A ₁	4 954	4 954	16'3"	16'3"
A ₂	5 764	6 002	18'11"	19'8"
B	5 152	5 339	16'11"	17'6"
C	3 428	3 428	11'3"	11'3"
C ₁	3 318	3 318	10'11"	10'11"
C ₂	1 768	1 768	5'10"	5'10"
C ₃	3 760	3 834	12'4"	12'7"
D	2 764	2 764	9'1"	9'1"
E	1 210	1 210	4'0"	4'0"
F	4 175	4 175	13'8"	13'8"
G	1 670	1 670	5'6"	5'6"
H	1 610	1 688	5'3"	5'6"
I	608	608	2'0"	2'0"
J	2 778	2 856	9'1"	9'4"
K	2 102	2 181	6'11"	7'2"
L	677	686	2'3"	2'3"
M	6 559	6 592	21'6"	21'8"
N	8 105	8 105	26'7"	26'7"
N ₁	4 079	4 037	13'5"	13'3"
O	2 700	2 900	8'10"	9'6"
P	2 490	2 706	8'2"	8'11"
R	512	513	1'8"	1'8"
R ₁	634	635	2'1"	2'1"
U	3 257	3 310	10'8"	10'10"
V	2 258	2 216	7'5"	7'3"
V*	-----	2 258	-----	7'5"
W	2 859	2 941	9'5"	9'8"
W*	-----	2 859	-----	9'5"
X	456	456	1'6"	1'6"
X ₁	581	582	1'11"	1'11"
X ₂	659	659	2'2"	2'2"
Y	2 258	2 216	7'5"	7'3"
Y*	-----	2 258	-----	7'5"
Z	2 859	2 941	9'5"	9'8"
Z*	-----	2 859	-----	9'5"
a ₁	23.5°	23.5°	23.5°	23.5°
a ₂	74°	70°	74°	70°
a ₃	45°	45°	45°	45°

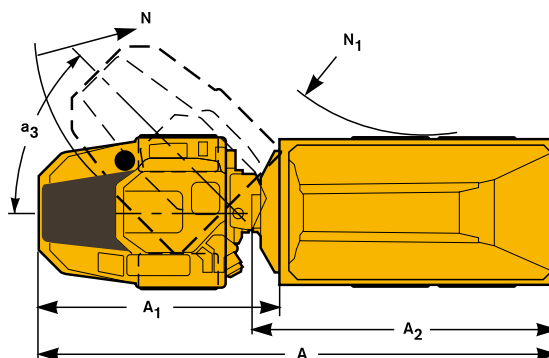
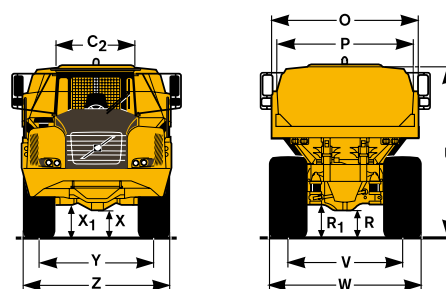
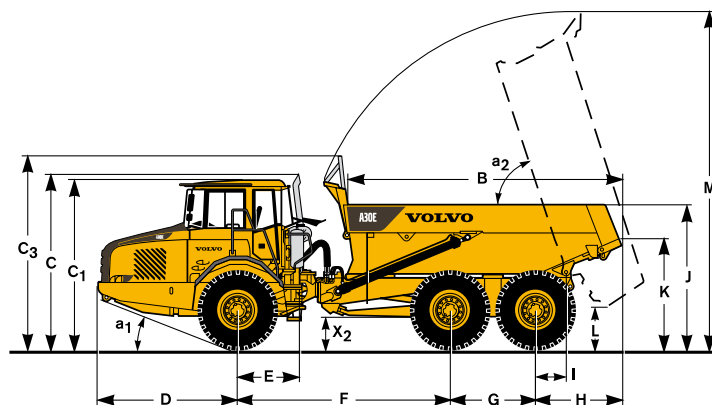

A25E: Macchina scarica con 23,5 R25
A30E: Macchina scarica con 750/65R25
*) A30E con pneumatici 23,5 R25 optional

Capacità di carico

	A25E		A30E	
Cassone standard				
Capacità di carico	24 000 kg	26.5 sh tn	28 000 kg	31.0 sh tn
Cassone, raso	11,7 m ³	15.3 yd ³	13,6 m ³	17.8 yd ³
Cassone, colmo	15,0 m ³	19.6 yd ³	17,5 m ³	22.9 yd ³
Con sponda posteriore sporgente				
Cassone, raso	12,0 m ³	15.7 yd ³	13,8 m ³	18 yd ³
Cassone, colmo	15,3 m ³	20 yd ³	18,0 m ³	23.5 yd ³
Con sponda posteriore sporgente				
Cassone, raso	12,1 m ³	15.8 yd ³	14,0 m ³	18.3 yd ³
Cassone, colmo	15,6 m ³	20.4 yd ³	18,1 m ³	23.7 yd ³
Con sponda posteriore doppia				
Cassone, raso	12,1 m ³	15.8 yd ³	- m ³	- yd ³
Cassone, colmo	15,6 m ³	20.4 yd ³	- m ³	- yd ³

Pesi

	A25E		A30E	
Pneumatici	23.5R25		750/65R25	
Peso operativo, scarico				
Anteriore	12 160 kg	26 808 lb	12 500 kg	27 557 lb
Posteriore	9 400 kg	20 723 lb	10 560 kg	23 280 lb
Totale	21 560 kg	47 531 lb	23 060 kg	50 838 lb
Carico utile	24 000 kg	52 910 lb	28 000 kg	61 729 lb
Peso complessivo				
Anteriore	14 140 kg	31 173 lb	14 990 kg	33 047 lb
Posteriore	31 420 kg	69 269 lb	36 070 kg	79 520 lb
Totale	45 560 kg	100 442 lb	51 060 kg	112 568 lb

Il peso operativo comprende anche quello dei fluidi e dell'operatore.

Pressione al Suolo

	A25E		A30E			
Pneumatici	23.5R25		750/65R25		23.5R25	
Scarico						
Anteriore	123 kPa	17.8 psi	101 kPa	14.6 psi	127 kPa	18.4 psi
Posteriore	48 kPa	7.0 psi	43 kPa	6.2 psi	54 kPa	7.8 psi
Carico						
Anteriore	144 kPa	20.8 psi	121 kPa	17.5 psi	152 kPa	22.0 psi
Posteriore	159 kPa	23.0 psi	146 kPa	21.2 psi	183 kPa	26.5 psi

Velocità

	A25E		A30E	
Avanti				
1	8 km/h	5.0 mph	8 km/h	5.0 mph
2	12 km/h	7.5 mph	12 km/h	7.5 mph
3	22 km/h	13.6 mph	22 km/h	13.6 mph
4	31 km/h	19.3 mph	31 km/h	19.3 mph
5	40 km/h	24.8 mph	40 km/h	24.8 mph
6	53 km/h	32.9 mph	53 km/h	32.9 mph
Indietro				
1	8 km/h	5.0 mph	8 km/h	5.0 mph
2	13 km/h	8.1 mph	13 km/h	8.1 mph

Capacità di riempimento

	A25E		A30E	
Carter	40 litri	10.6 US gal	40 litri	10.6 US gal
Serbatoio carburante	400 litri	106.0 US gal	400 litri	106.0 US gal
Impianto di raffreddamento	115 litri	30.4 US gal	115 litri	30.4 US gal
Trasmissione, totale	41 litri	11.0 US gal	41 litri	11.0 US gal
Dropbox	8,5 litri	2.2 US gal	8,5 litri	2.2 US gal
Assali, anteriore/posteriore	33 litri	8.7 US gal	33 litri	8.7 US gal
Primo assale	34 litri	9.0 US gal	34 litri	9.0 US gal
Serbatoio idraulico	175 l litri	46.0 US gal	175 litri	46.0 US gal

Materiale cassone

Frontale	8 mm	0.31"
Laterale	12 mm	0.47"
Parte inferiore	14 mm	0.55"
Scivolo	14 mm	0.55"
Forza di piegamento	1000 N/mm ²	145 000 psi
Forza tensile	1250 N/mm ²	181 000 psi
Durezza	400 HB	